



Installation Instructions

Pulsar 600 (Experimental)



AeroLEDs, LLC
 8475 W. Elisa St.
 Boise, ID, 83709
 208-850-3294

NOTE: A printed copy of this document may not be the latest revision. It is the responsibility of the user to ensure that the latest revision is used. The latest revision of this document may be printed from the AeroLEDs electronic document repository. Revision history follows on page 2

This document contains proprietary information of AeroLEDs. Neither receipt nor possession thereof confer any right to reproduce or use, or disclose, in whole or in part, any such information without written permission from AeroLEDs.

Approval	Name	Intent	
Author	Jennifer Blanchfield	Installation instructions for Experimental Pulsar 600 light assemblies (01-1100)	
Check	Nate Calvin		
Quality	Mark McCormack		
Date:	December 06 2024		
Status: Released	Typed signatures indicate approval. Handwritten, or electronic signature approval of this document is on file at AeroLEDs, Boise, Idaho.	Document Number 0011-0006	Revision B



REVISION RECORD

Rev	Description	Date	Author
B	Updated Logo, part name changes; added P65 warning	12/06/2024	J. Blanchfield
A	Format, instruction, and image updates	6/12/2020	J. Blanchfield
IR	Original Version	07/02/2015	D. Wilkinson

TABLE OF CONTENTS

1	System Description	4
2	Model Numbers	4
3	Airworthiness Limitations	4
3.1	Instructions for Continued Airworthiness.....	4
4	Installation	5
4.1	Installation Procedures	5
4.2	Troubleshooting.....	5
5	Diagrams	6
5.1	Mounting diagram.....	6
5.2	Bracket diagram	7
5.3	Wiring diagram	7

1 System Description

The Pulsar 600 LED light offers the capability to have three functions in one unit: Navigation, Anti-Collision Strobe, and Position. These lights are designed for installation on any aircraft wingtip, aft stabilizer, or fuselage.

TSO-C30c TYPE I, II & III – APPROVED

TSO-C96a CLASS II – APPROVED

2 Model Numbers

Model	Part Number	Description	Voltage (V)	Current (Amps)			Weight (oz)
				Strobe		Nav	
				AVG	Peak		
Pulsar 600 (12V) 01-1100-12	01-1100-12-L	Navigation, Position, Anti-collision	14	1.2	9.9	1.6	8.7*
	01-1100-12-R						
Pulsar 600 (24V) 01-1100-24	01-1100-24-L	Navigation, Position, Anti-collision	28	0.8	6.3	0.8	
	01-1100-24-R						

Table 1

Note: All listed specifications shown are per pair

*Includes weight of two mounting brackets (.7 oz)

3 Airworthiness Limitations

The Airworthiness Limitations section is FAA approved and specifies maintenance required under **14 CFR, §43.16** and **14 CFR, §91.403** of the Federal Aviation Regulations unless an alternative program has been FAA approved. There are no additional airworthiness limitations.

3.1 Instructions for Continued Airworthiness

Pulsar light assemblies contains no user serviceable items. Should any LED fail, unit must be replaced.

Interval	Inspection	Remedy	Notes
Pre-Flight	<ul style="list-style-type: none"> Perform a functional check and observe that all LEDs are illuminated 	<ul style="list-style-type: none"> If all LEDs are not illuminated replace light as soon as is practicable 	<ul style="list-style-type: none"> Lights are not user serviceable. Lights are very bright and to reduce eye strain during inspection use an optical filter such as dark glasses or welding goggles.
Annually, unless the OEM specifies a shorter interval	<ul style="list-style-type: none"> Perform a functional check and observe that all LEDs are illuminated Check mounting, connections, and wire integrity 	<ul style="list-style-type: none"> If all LEDs are not illuminated, the light must be replaced Adjust or replace wiring, and connectors as required 	

4 Installation

Consult **14CFR, §43.13-1B** for guidance on acceptable methods, techniques, and practices. Pulsar lights mount onto a supplied bracket, which mounts into existing holes on aircraft (see mounting diagram). For retrofit installation existing circuit breaker or fuse may typically be used. Procedures contained herein are not intended to conflict with procedures set forth by aircraft OEM, nor do they supersede FAA manuals and FAA regulations.

4.1 Installation Procedures

1. Disconnect aircraft power or disable applicable circuit breakers
2. Ensure all switches are in the OFF position
3. Reference OEM manual
 - a. Remove existing light assembly (retain hardware)
 - b. Bypass or remove existing high voltage power supply (if applicable)

NOTE: Connecting light to high voltage power supply will result in permanent damage and will void warranty

4. Install suitable connectors and/or splices to connect light assemblies in accordance with wiring diagram(s)
5. Using the appropriate hardware install as per section **5.1 Mounting diagram**
6. Re-connect aircraft power or enable applicable circuit breakers
7. Verify proper operation of LED light(s)
8. Record installation with logbook entry

Note: Shielded cable is recommended although not required for installation.

It is recommended that ground connections for all lights be made at a single location on aircraft central ground bus. This “single point ground” scheme helps to eliminate ground loops and ground bounce that can occur when using airframe as a ground.

4.2 Troubleshooting

1. Check for proper voltage at power input wire to light
2. Ensure light is adequately grounded
3. Check for continuity in wiring and connections
4. If wiring is verified, remove light and bench-check with appropriately sized power supply

If above actions do not correct problem, contact AeroLEDs tech support at 1-208-850-3294 for a resolution.

⚠ WARNING: This product can expose you to chemicals including Methylene Chloride which is known to the State of California to cause cancer, and Bisphenol A, which is known to the State of California to cause birth defects or other reproductive harm. For more information go to www.P65Warnings.ca.gov

5 Diagrams

5.1 Mounting diagram

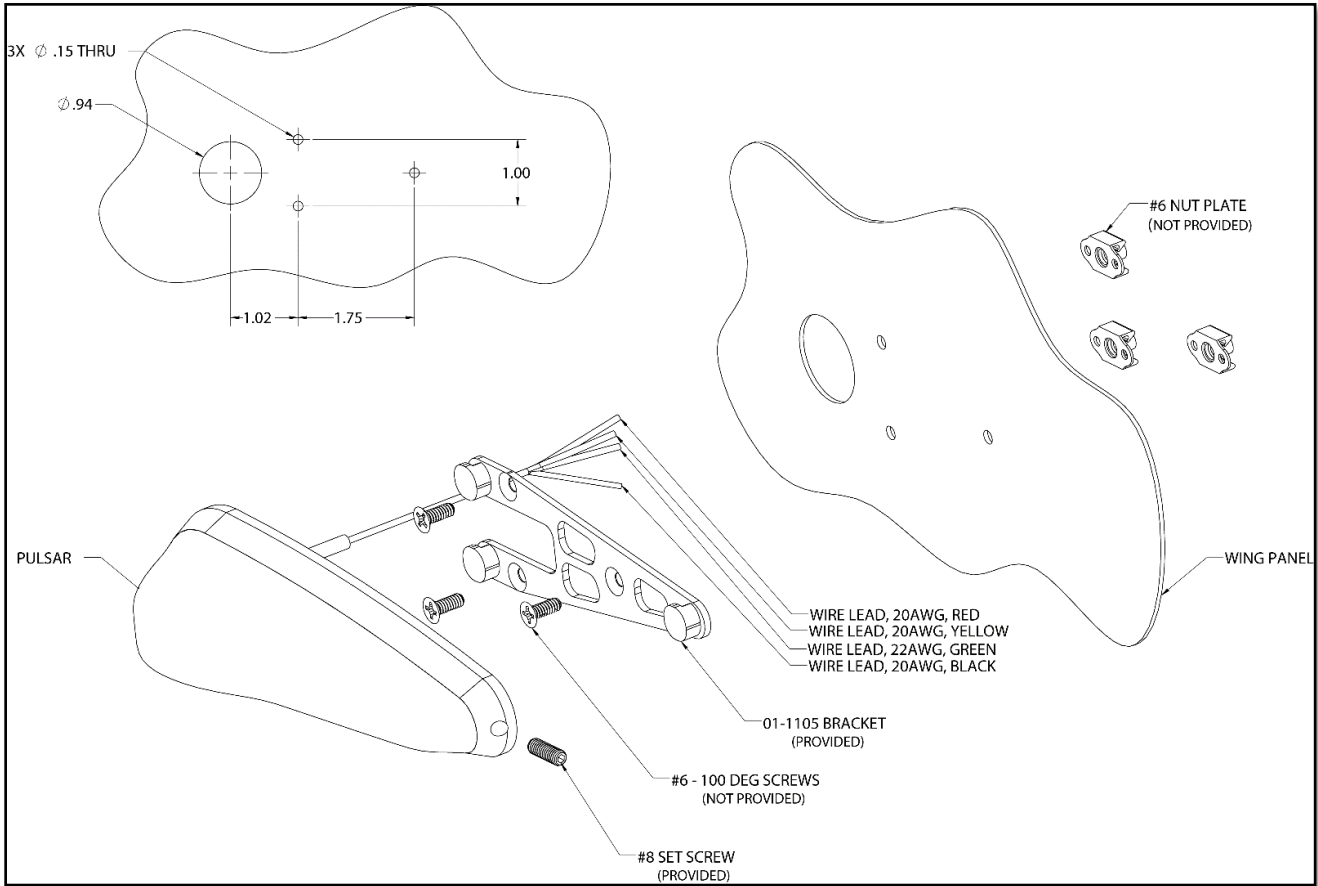

Figure 1

5.2 Bracket diagram

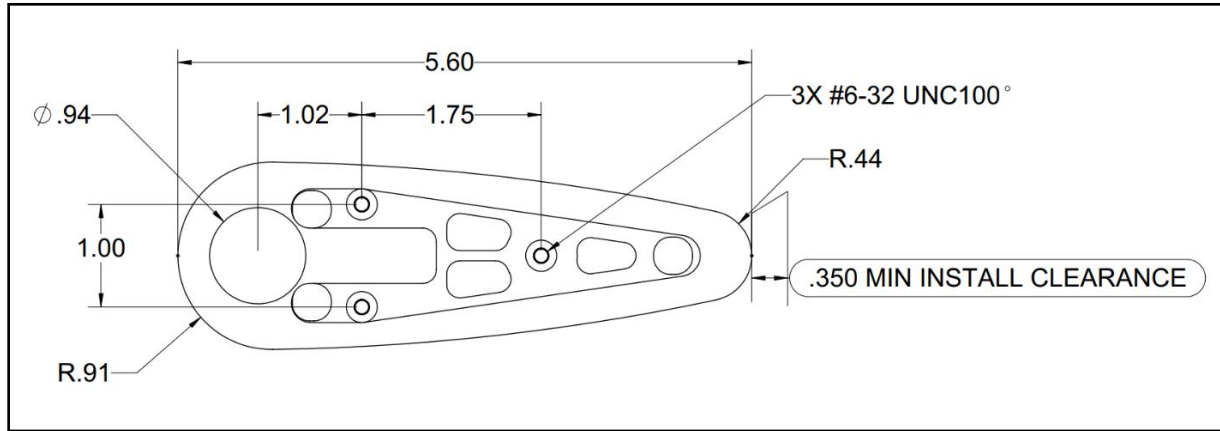

Figure 2

5.3 Wiring diagram

WARNING: Do not connect strobe power wire to a Xenon strobe power pack. This will damage light and voids the warranty.

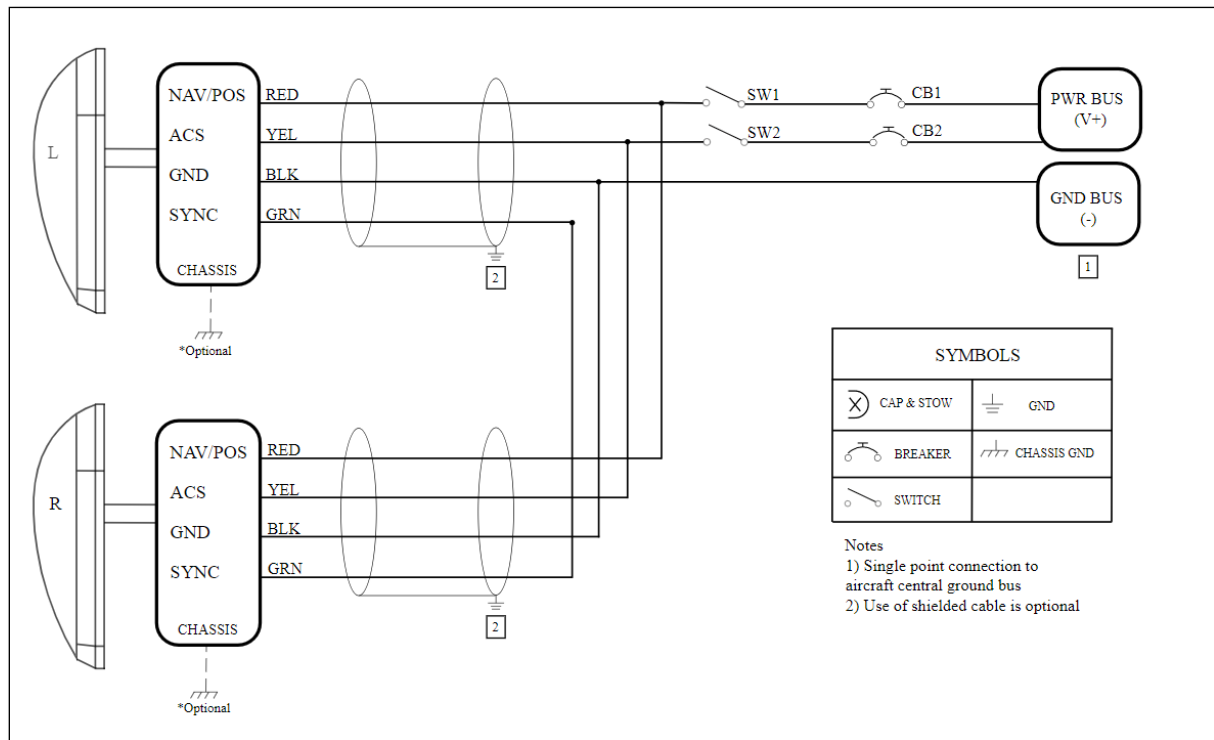

Figure 3